

GRATING HIDDEN FOR CLARITY OF DIMENSIONS

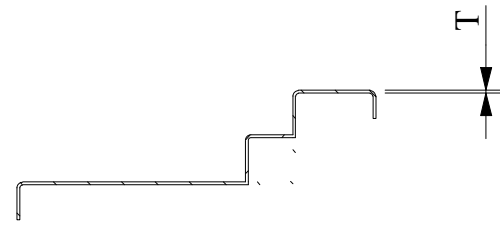

SECTION VIEW Z-Z
SCALE (1 : 4)
VIEW MIRRORED OPP SIDE

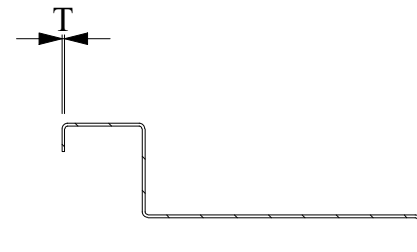
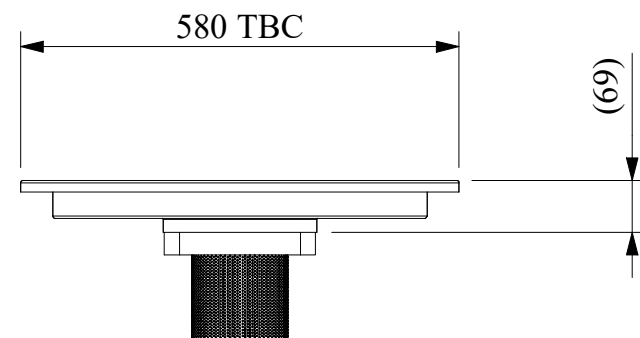

SECTION VIEW Y-Y
SCALE (1 : 4)
VIEW ROTATED AND ENLARGED
PROFILE MIRRORED OPP SIDE

ALL MATERIAL FOR MOP PIT
SHEET STAINLESS STEEL
#4 FINISH

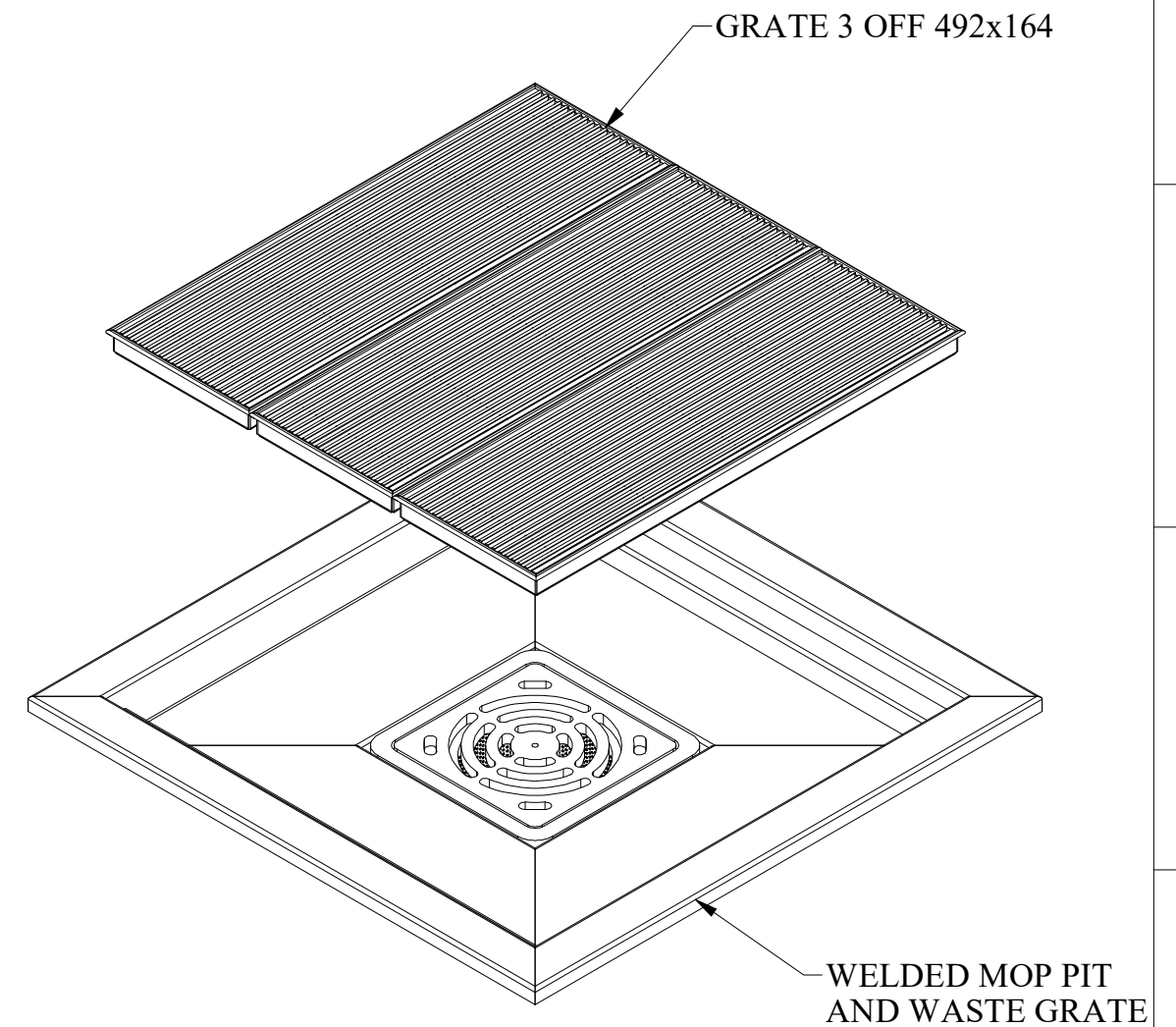

ISO VIEW

GENERAL NOTES:

1. ALL DIMENSIONS IN MM UNLESS NOTED OTHERWISE
2. REMOVE ALL SHARP EDGES AND DEBURR HOLES
3. SURFACE FINISH N10 UNLESS SPECIFIED OTHERWISE
4. DRAWN TO AS 1100

REV TABLE				
REV	DATE	DESCRIPTION	DRAWN BY	CHECKED BY
1	14/04/26	FIRST DRAFT	Y. SHAH	A. YOUNG

Marko Stainless & Aluminium	YH MECHANICAL DRAFTING SERVICES
1091 Project: MOP PITS	DATE: 14/04/2026 DRAWN BY: Y. SHAH
TOLERANCES LINEAR ± 0.5 ANGULAR ± 0.2	MATERIAL: 40.9 kg
	PART NO: Mop Pit 2 SCALE: 1 : 10 SHEET NO: 1 / 1
	REV: 01 A3