

DETAIL VIEW A
SCALE (1:2)

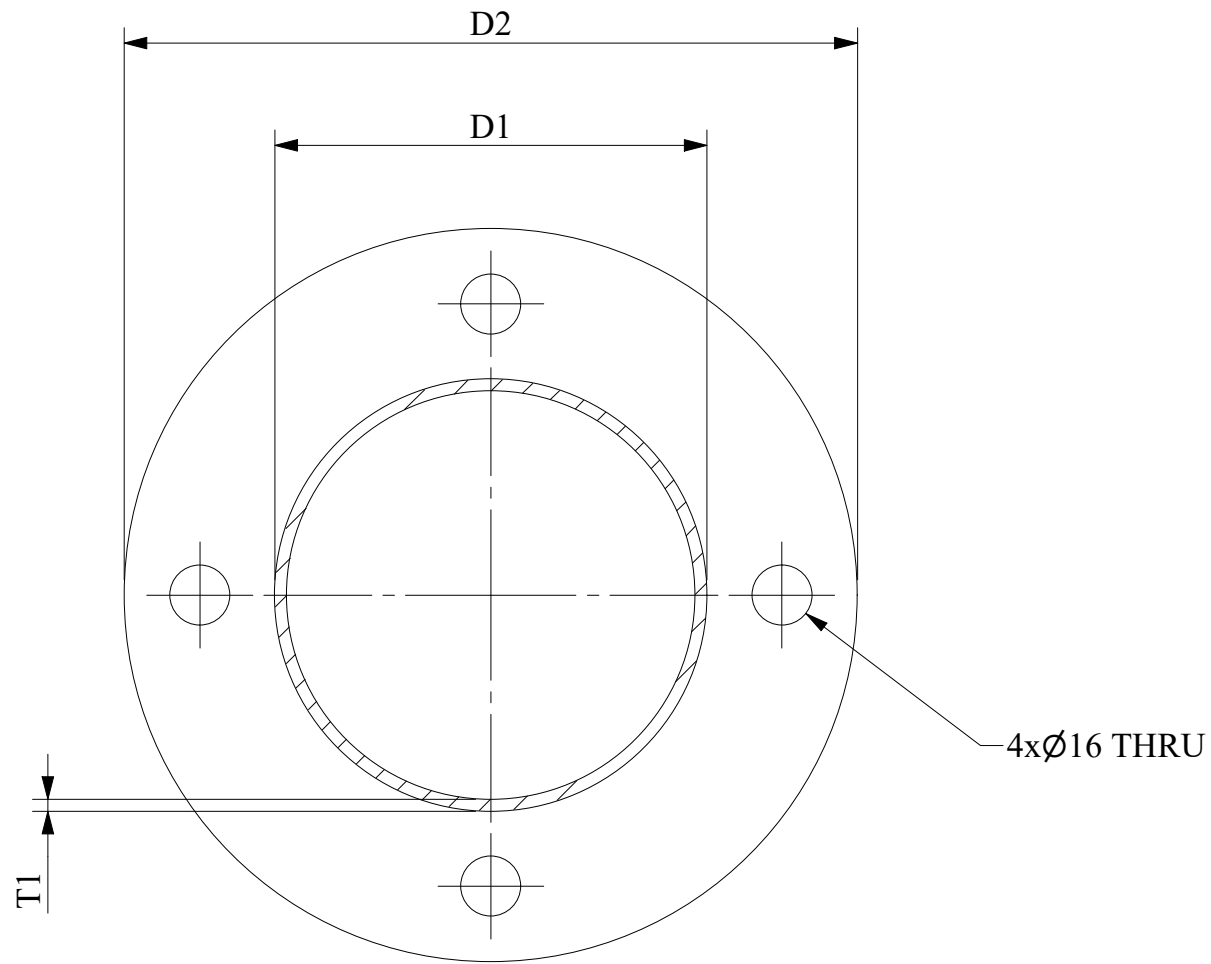

SECTION VIEW Z-Z
SCALE (1:2)

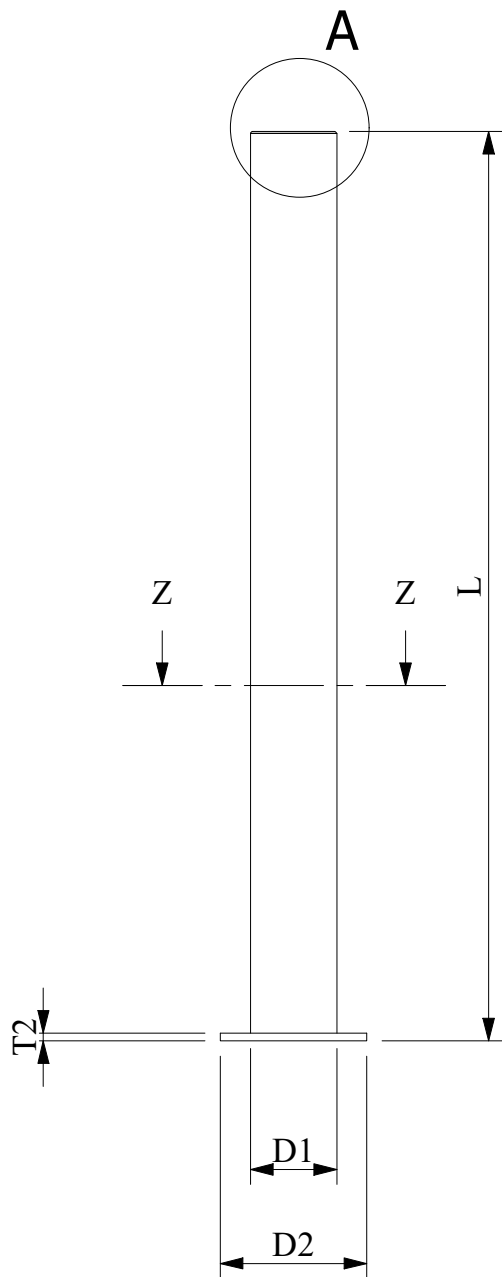
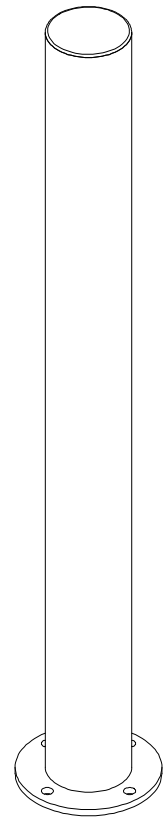

ISO VIEW

ALL MATERIAL STAINLESS STEEL
GRIT 240 #4 FINISH

GENERAL NOTES:

1. ALL DIMENSIONS IN MM UNLESS NOTED OTHERWISE
2. REMOVE ALL SHARP EDGES AND DEBURR HOLES
3. SURFACE FINISH N10 UNLESS SPECIFIED OTHERWISE
4. DRAWN TO AS 1100

REV TABLE				
REV	DATE	DESCRIPTION	DRAWN BY	CHECKED BY
1	14/04/26	FIRST DRAFT	Y. SHAH	A. YOUNG

Marko Stainless & Aluminium	YH MECHANICAL DRAFTING SERVICES
1090 Project: BOLLARDS	DATE: 13/04/2026 DRAWN BY: Y. SHAH
TOLERANCES LINEAR ± 0.5 ANGULAR ± 0.2	MATERIAL: 11.9 kg
PART NO: Base Plate Bollard	
SCALE: 1:10 SHEET NO: 1/1 REV: 01 A3	