

DETAIL VIEW A
SCALE (1:2)

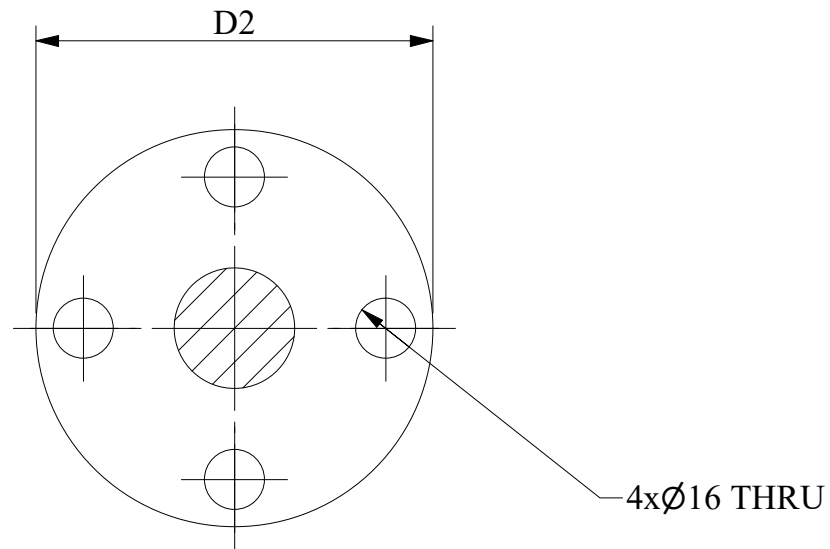

SECTION VIEW Z-Z
SCALE (1:2)

4xØ16 THRU

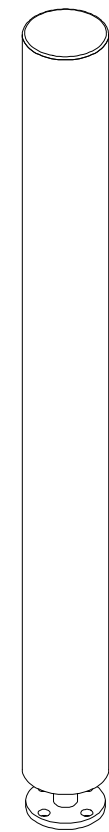

ISO VIEW

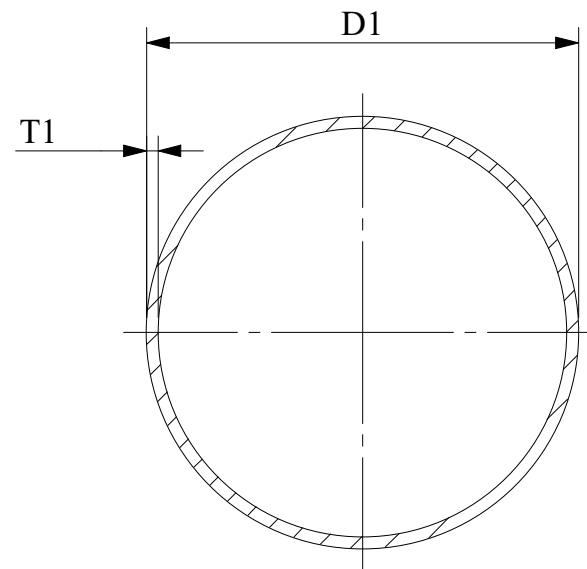
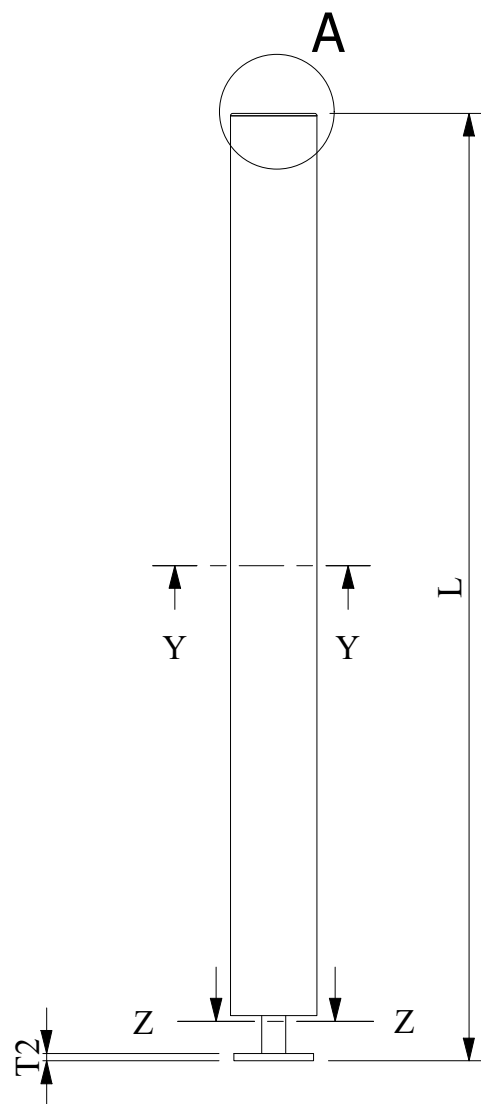

SECTION VIEW Y-Y
SCALE (1:2)

ALL MATERIAL STAINLESS STEEL
GRIT 240 #4 FINISH

GENERAL NOTES:

1. ALL DIMENSIONS IN MM UNLESS NOTED OTHERWISE
2. REMOVE ALL SHARP EDGES AND DEBURR HOLES
3. SURFACE FINISH N10 UNLESS SPECIFIED OTHERWISE
4. DRAWN TO AS 1100

REV TABLE				
REV	DATE	DESCRIPTION	DRAWN BY	CHECKED BY
1	14/04/26	FIRST DRAFT	Y. SHAH	A. YOUNG

Marko Stainless & Aluminium		YH MECHANICAL DRAFTING SERVICES		
1090	DATE: 13/04/2026	BOLLARD ASSY 5		
Project: BOLLARDS	DRAWN BY: Y. SHAH	PART NO: Screw Base Bollard		
TOLERANCES LINEAR ± 0.5 ANGULAR ± 0.2	MATERIAL: 12.5 kg	SCALE: 1:10	REV: 01	
		SHEET NO: 1/1	A3	